

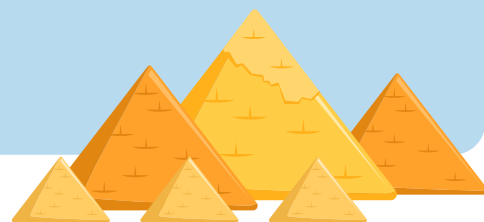























Rotkäppchen / Le Petit Chaperon Rouge / Caperucita Roja / 小红帽

Kan du skrive titlen "Den Lille Rødhætte" på et andet sprog?



Det hieroglyfiske alfabet

	A		I		Q
	B		J		R
Brug 'k' eller 's' afhængigt af lyd	C		K		S
	D		L		T
	E		M		U, V, W
	F		N		X
	G		O		Y
	H		P		Z

Mein Name / Mon nom:

Rotkäppchen / Le Petit Chaperon Rouge / Caperucita Roja / 小红帽

Kan du skrive titlen "Den Lille Rødhætte" på et andet sprog?



Kategoriseringsspil med farver



red	pango / mangu	noir	mā
schwartz	whero	green	blanche
grön	kākāriki	bleu	vit
svart	yellow	white	blau

Mein Name / Mon nom:

Rotkäppchen / Le Petit Chaperon Rouge / Caperucita Roja / 小红帽

Kan du skrive titlen "Den Lille Rødhætte" på et andet sprog?



Kategoriseringsspil med farver



jaune	blue	gelb	röd
grün	kikorangi	blå	weiß
gul	kowhai	black	vert
rot	rouge		

Mein Name / Mon nom:

Rotkäppchen / Le Petit Chaperon Rouge / Caperucita Roja / 小红帽

Kan du skrive titlen "Den Lille Rødhætte" på et andet sprog?

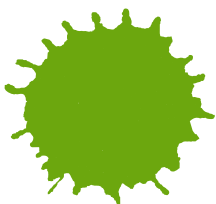
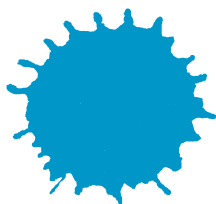
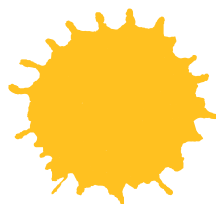
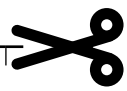
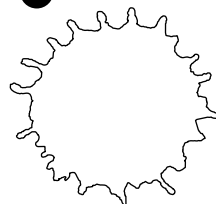
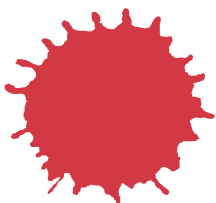
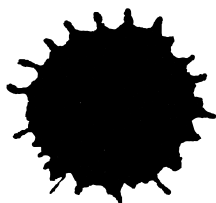

Kategoriseringsspil med farver

Mein Name / Mon nom:

Rotkäppchen / Le Petit Chaperon Rouge / Caperucita Roja / 小红帽

Kan du skrive titlen "Den Lille Rødhætte" på et andet sprog?



Puslehistorie



Später an dem selben Tag kam Rotkäppchen zum Großmutter's Haus. Die Tür war offen und Rotkäppchen ging herein. Im Bett lag die Großmutter, aber sie sah merkwürdig aus.

Rotkäppchen fragte: "Aber Großmutter! Was hast du für große Augen?"

Der Wolf sagte: "Damit ich dich besser sehen kann!"

Rotkäppchen fragte: "Aber Großmutter! Was hast du für große Ohren?"

Der Wolf sagte: "Damit ich dich besser hören kann!"

Rotkäppchen fragte: "Aber Großmutter! Was hast du für große Hände?"

Der Wolf sagte: "Damit ich dich besser packen kann!"

Rotkäppchen fragte: "Aber Großmutter! Was hast du für ein großes Maul?"

Der Wolf sagte: "Damit ich dich besser fressen kann!"

Und dann verschlang der Wolf das Rotkäppchen.

Eines Tages sprach seine Mutter zu ihm: "Rotkäppchen! Hier ist ein Korb mit Kuchen und Wein für die Großmutter. Sie ist krank und schwach und liegt im Bett. Gehe sie besuchen. Aber du darfst nicht im Wald herumrennen."

As soon as the wolf had finished this tasty bite, he climbed back into bed, fell asleep, and began to snore very loudly. A huntsman was just passing by. He thought it strange that the old woman was snoring so loudly, so he decided to take a look. He stepped inside, and in the bed, there lay the wolf that he had been hunting for such a long time. "He has eaten the grandmother, but perhaps she still can be saved. I won't shoot him," thought the huntsman. So, he took a pair of scissors and cut open his belly. He had cut only a few strokes when he saw the red cap shining through. He cut a little more, and the girl jumped out and cried: "Oh, I was so frightened! It was so dark inside the wolf's body!" And then the grandmother came out alive as well.

Mein Name / Mon nom:

Rotkäppchen / Le Petit Chaperon Rouge / Caperucita Roja / 小红帽

Kan du skrive titlen "Den Lille Rødhætte" på et andet sprog?



Puslehistorie



Le Petit Chaperon Rouge cueillait des fleurs pour sa grand-mère.

Le Loup courait vers la maison de la grand-mère. Il frappait à la porte. "Qui est là ?"

"C'est le Petit Chaperon Rouge." Le loup entra. Il avalait la grand-mère et se couchait dans son lit.

Rødhætte hentede i en fart nogle store sten og puttede dem ind i maven på ulven.

Da ulven vågnede, var den meget tørstig. Den løb straks ned til brønden, men fordi dens mave var fyldt med sten, faldt den i brønden og døde. De var alle tre meget glade. Bedstemoderen spiste kage og drak vin og kom igen til hæfterne, og lille Rødhætte lovede sig selv, at hun aldrig mere ville løbe ind i skoven, når hendes mor havde forbudt hende det.

"Det skal jeg nok", sagde Rødhætte. Bedstemoren boede ude i skoven, en halv times gang fra landsbyen. Da Rødhætte kom ind i skoven, mødte hun ulven, men hun var slet ikke bange, for hun anede ikke, hvor slem den var. "Goddag, Rødhætte," sagde den. "Goddag," svarede hun. "Hvor skal du hen så tidligt?" - "Jeg skal til bedstemor." - "Hvad er det, du har under forklædet?" - "Det er kage og vin. Vi har bagt i går, og nu skal stakkels, gamle bedste også have noget." - "Hvor bor din bedstemor, lille Rødhætte?" - "Åh, det er vel et kvarters gang herfra. Hendes hus ligger under de tre store egetræer, du ved nok." - "Dét er én rigtig lækker lille mundfuld," tænkte ulven ved sig selv, "hun vil nok smage bedre end den gamle. Nu vil jeg bære mig rigtig snildt ad, så jeg får fat i dem begge to."

Den fulgte nu Rødhætte et lille stykke på vej, og lidt efter sagde den til hende:

"Se engang de dejlige blomster, Rødhætte, du ser dig slet ikke om. Du hører vist ikke engang, hvor kønt fuglene synger." Rødhætte så sig om og tænkte: "Bedstemor vil sikkert blive glad for en buket blomster."

Once upon a time there was a sweet little girl, who lived with her mother.

Everyone who saw her liked her, but most of all her grandmother, who did not know what to give the child next. Once she gave her a little cap made of red velvet. Because it suited her so well, and she wanted to wear it all the time, she came to be known as Little Red Riding Hood.

Mein Name / Mon nom:

Rotkäppchen / Le Petit Chaperon Rouge / Caperucita Roja / 小红帽

Kan du skrive titlen "Den Lille Rødhætte" på et andet sprog?



Puslehistorie



Mein Name / Mon nom:

Sproguge i 7. klasse: Elevark 4

Rotkäppchen / Le Petit Chaperon Rouge / Caperucita Roja / 小红帽

Kan du skrive titlen "Den Lille Rødhætte" på et andet sprog?



Adjektivjagt

Hvordan vil du beskrive de tre karakterer?

Find adjektiver på forskellige sprog og skriv adjektiverne ved de tre billeder.

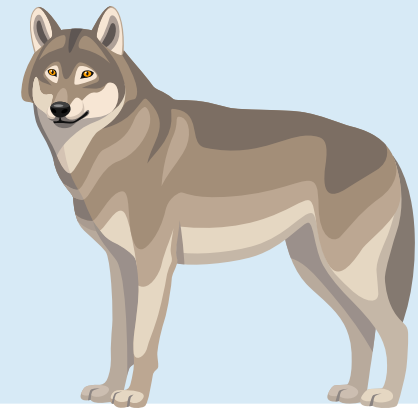
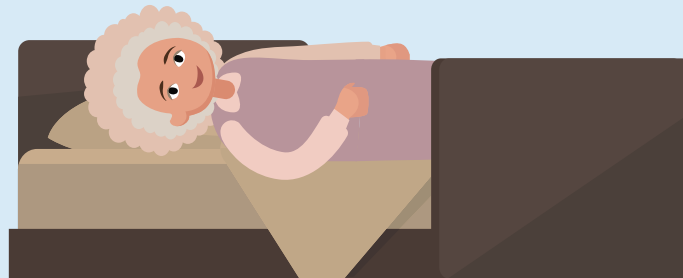
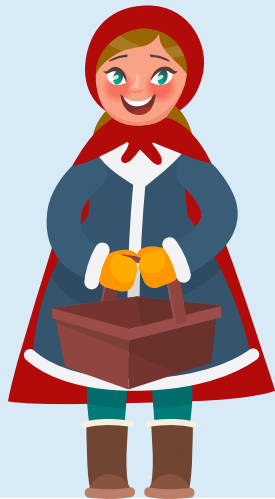

Mein Name / Mon nom:

Rotkäppchen / Le Petit Chaperon Rouge / Caperucita Roja / 小红帽

Kan du skrive titlen "Den Lille Rødhætte" på et andet sprog?

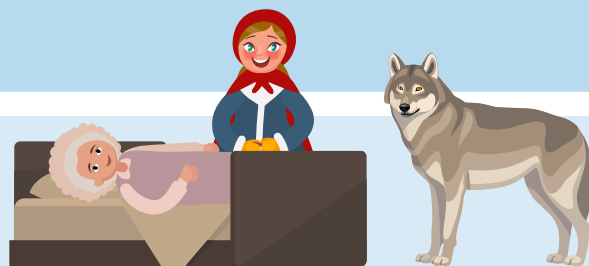

Personkarakteristik

Kan du gætte, hvilke sprog, ordene er på?

Sprog 1	Sprog 2	Sprog 3	Sprog 4
vieille	sjuk	böse	korkak
malade	gammal	ängstlich	hasta
méchant	rädd	alt	yaşlı
a peur	ond	krank	kötü

Kan du gætte, hvad ordene betyder? Skriv ordene ind i skemaet.

	gammel	bange	syg	ond
Sprog 1				
Sprog 2				
Sprog 3				
Sprog 1				

Mein Name / Mon nom:

Rotkäppchen / Le Petit Chaperon Rouge / Caperucita Roja / 小红帽

Kan du skrive titlen "Den Lille Rødhætte" på et andet sprog?



Rødhættes kurv

Skriv og tegn det, som Den Lille Rødhætte har i kurven på forskellige sprog.

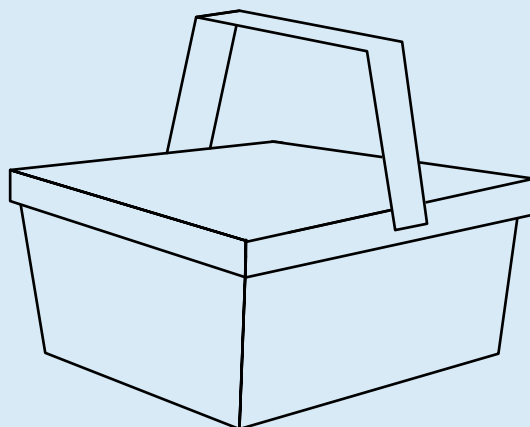
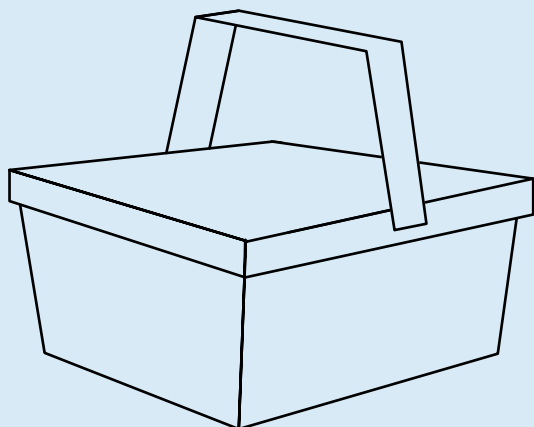
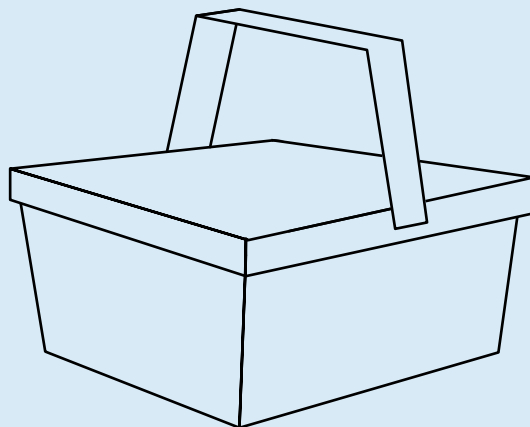
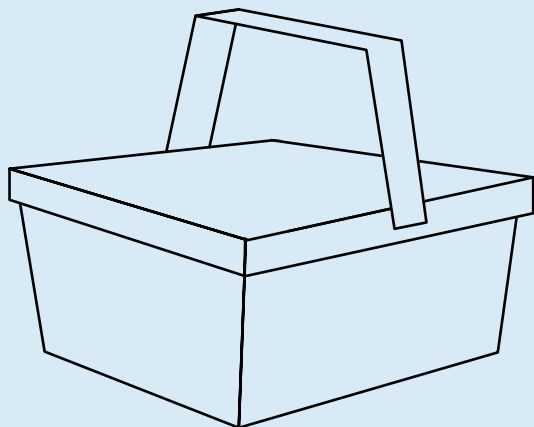

Mein Name / Mon nom:
